

Measuring transducer, frequency type to correct for wheel/tyre wear on rail vehicles

- Straightforward application
- Suitable for severe operating conditions
- Compact construction
- Tyre diameter setting by means of tamper-evident drum scale
- For all commercial tyre diameters
- Galvanic isolation between sensor input and operating voltage to the output signal
- Meet high EMC-requirements **CE** requirements
- Short-circuit-proof output selectable from 0 ... 10 V/DC, 2 ... 10 V/DC, 0 ... 20 mA, 4 ... 20 mA
- Operating characteristics displayed by integrated LED
- Flame-inhibiting and self-extinguishing body
- Suitable speed sensors are available (NORIS devices FA../ FT..)



Abbildung
VF502KD1-I2



Germanischer Lloyd

Measuring transducers of series 5

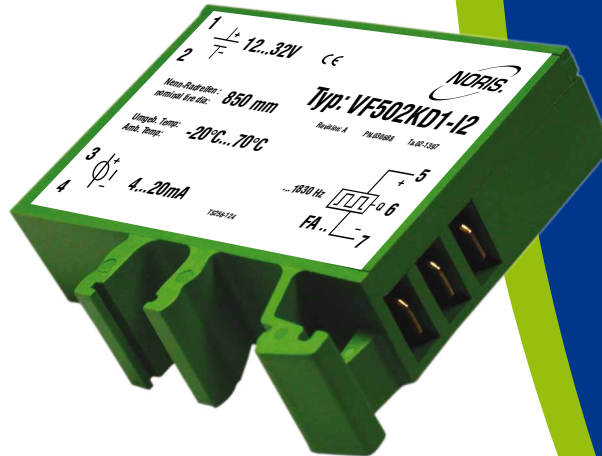
Measuring transducers of the Series 5 are designed to convert electric input values into standardised output signals.

Principle of operation: The transducer signal measured at the converter input is converted into a standardised output signal that is proportional to the input and lends itself to further customised processing, for instance, in a machine controller.

General notes on Type VF5xxKDx-x

Description VF5..KD..

The type VF5..KD.. is designed to compensate signal output of the speed sensor to allow for the diameter of the tyre, when worn. The corrected signal output then reflects the true speed, whereas operational wear and turning-down of the tread would result in high readings.

Details VF5..KD.-x.

- Signal input for a NORIS standard frequency signal
- Suitable to evaluate sensors of the FT.. and FA.. series
- Setting of tyre diameter by means of drum scale directly in mm
- Input range: 0 ... 10.000 Hz
- The upper-range frequency is factory-adapted (corresponding to the maximum speed readings based on the diameter of the tyre when new)
- Correction range to suit customer's requirements
To avoid triggering errors the frequency full range set in factory must be the highest frequency of the measuring chaine.

Electric isolation

The operating voltage and sensor input are electrically isolated from the output signal. Therefore, multiple operation of amplifiers and evaluation devices is possible at the same operating voltage and from only one sensor.

Output signal

The output signal generated is a standardized voltage of 0 ... 10 V/DC or 2 ... 10 V/DC or, respectively, a standardized current of 0 ... 20 mA or 4 ... 20 mA. The output signal follows the input signal strictly linearly (deviation < 0.1%).

The output signal can be used to supply additional devices, such as indicating instruments and limit-value switches. Attention should be paid to the maximum driver capability of the output.

Input signal

The NORIS standard signal corresponds to a rectangular voltage with an amplitude that corresponds to the operating voltage applied. This results in a signal that is immune to interference and tolerates considerable changes in the operating voltage. The operating voltage required by the sensor is provided by the measuring transducer.

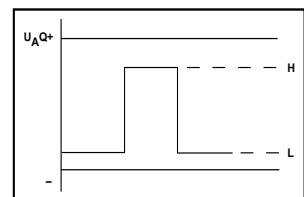

Operating status display by LED

The green LED will be lit when the operating voltage is applied and the device is working normally.

Technical Data

Series VF5..KD.-.	
Operating Voltage	$U_o=9 \dots 32$ V/DC, $U_R=24$ V/DC
Ripple	$< 20\%$ U_o
Reverse voltage protection	Integrated
Overvoltage	2.5 times U_R up to 2 ms
Voltage drops	100% up to 10 ms
Power consumption	Approx. 50 mA (24 V/DC)
Galvanic isolation	Between input signal and operating voltage to the output signal
Input signal	NORIS standard signal from speed sensors FT.. / FA..
Input overloading	$< U_R$
Input resistance	Approx. 5,6 k Ω
Input current	< 5 mA
Diameter of wheel	Can be set on tamper-evident drum scale in mm
Output VF5..KD.-G.	0 ... 10 V/DC (VF5..KD.-G1), 2 ... 10 V/DC (VF5..KD.-G2), short-circuit-proof, load current 20 mA max.
Output VF5..KD.-I.	0 ... 20 mA (VF5..KD.-I1), 4 ... 20 mA (VF5..KD.-I2), load resistance 0 ... 500 Ω max.
Noise voltage	Approx. 20 mV
Error class	IEC51-1 1.5%
Temperature sensitivity	$< \pm 0.1\%$ per 10 °K
Voltage sensitivity	$< \pm 0.1\%$ for 10% change in operating voltage
Load sensitivity	$< \pm 0.1\%$ for 50% change in load current
Reaction time	f=50 Hz / 0.25 s, f=100 Hz / 0.2 s, f=1 kHz / 0.1 s, f=10 kHz / 50 ms
Vibration resistance	IEC60068-T2-6 15g increased strain, characteristic 2 (10...100 Hz)
Shock resistance (impact)	DIN IEC60068-T2-27 300 m/s ² with 18 ms dwell time
Climatic test	IEC60068-T2-30
Operating temperature	-20 °C ... +70 °C
Storage temperature	-45 °C ... +85 °C
Humidity	RH 96% maximum
ESD	IEC61000-4-2 ± 8 kV
Electromagnetic field	IEC61000-4-3 10 V/m f=10 kHz ... 2000 MHz, 80% AM @ 1 kHz 10 V/m f=900 \pm 5 MHz, 50% AM @ 200 Hz 10 V/m f=1800 MHz \pm 5 MHz, 50% AM @ 200 Hz
Burst	IEC61000-4-4 ± 2 kV supply ± 1 kV sensor
Surge	IEC61000-4-5 sym. ± 1 kV ($R_f=2 \Omega$) asym. ± 2 kV ($R_f=2 \Omega$)
HF-susceptibility	IEC61000-4-6 3 V _{pp} , 80% AM @ 1 kHz f=0.01 ... 100 MHz
NF-susceptibility	IEC60553 3 V _{pp} 0.05 ... 10 kHz
Interference field intensity	Basis CISPR 16-1, 16-2 reduced characteristic
Connection	DIN EN 46244 flat connector, gold-plated A6.3 x 0.8
Protection class	DIN EN 60529 body IP20, terminals IP00
Mounting	Snap-fit on top-hat channel or G-channel
Installed position	Any
Body material	Thermoplastic polyester, green, DIN EN 5510, fire protection class V0
Weight	55 g
Standard supply	CE requirements complied with, DIN EN 61000-6-2, DIN EN 61000-6-4, DIN EN 50121-3-1, -2, -3, DIN EN 50155, meets interference emission standards to DIN EN 50081-1, -2, meets interference immunity standards to DIN EN 50082-2, approved by GL, BV, LR, DNV

Other Data

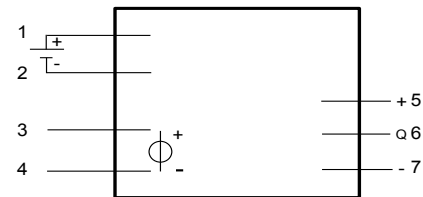
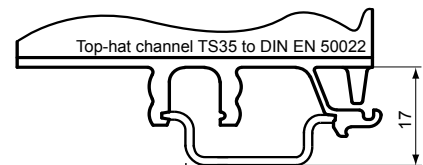
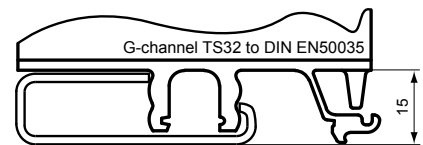
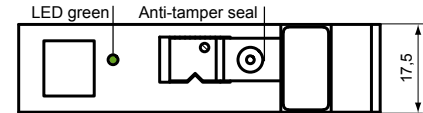
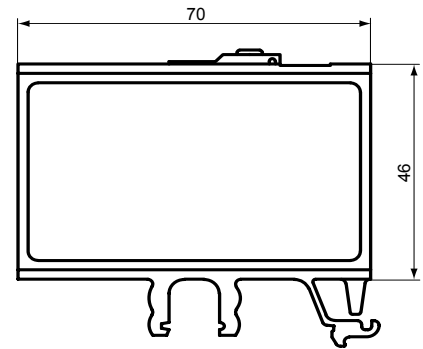

LED code

x = LED lighting
- = LED out
o = LED flashing

	Operating	LED green
x		x

Type key / variants

Frequency version:	00	01	02
Output: 0 ... 10 V/DC	VF500KDx-G1	VF501KDx-G1	VF502KDx-G1
Output: 2 ... 10 V/DC	VF500KDx-G2	VF501KDx-G2	VF502KDx-G2
Output: 0 ... 20 mA	VF500KDx-I1	VF501KDx-I1	VF502KDx-I1
Output: 4 ... 20 mA	VF500KDx-I2	VF501KDx-I2	VF502KDx-I2

speed and tyre diameter to be stated in order.

Device codes

V	Measuring transducer
F	Input signal
F	Frequency input for NORIS standard signal (sensors series FT / FA)
5	Type series
5	Type 5
00	Input range f_B / upper-range frequency f_E
00	f_B : 10 ... 100 Hz, f_E : 50 ... 100 Hz
01	f_B : 20 ... 1,000 Hz, f_E : 100 ... 1,000 Hz
02	f_B : 200 ... 10,000 Hz, f_E : 1,000 ... 10,000 Hz
KDx	Tyre / Maximum speed type
KDx	KDx with facility to set tyre diameter x = code for tyre size as a function of maximum speed readings (defined at time of order)
G1	Output 0 ... 10 V/DC, short-circuit-proof
G2	Output 2 ... 10 V/DC, short-circuit-proof
I1	Output 0 ... 20 mA
I2	Output 4 ... 20 mA

V F 5 01 KD99-I2 (VF501KD99-I2) order example



NORIS Automation GmbH
Muggenhofer Strasse 95
90429 Nuremberg
Germany

Tel.: +49 911 3201-220
Fax: +49 911 3201-150
sales@noris-group.com
www.noris-group.com