



Solutions for
Marine Automation

Content

Integrated ship solutions - everything from a single source	03
Our solutions - an overview	04
NORISYS 4 - the open automation platform	06
NORIMOS 4 - high performance, PLC-based alarm, monitoring and control system	09
NORIMOS 3500 - cost-effective, computer-based alarm, monitoring and control system	10
NORISTAR 4 - the propulsion control system for your ship	11
NORISTAR-EOT - engine order telegraph system	13
NORISYNC 4 - power management solutions	14
Energy storage solutions - for the most efficient use of energy	15
myNORIS - smart automation solutions for small and mid-sized applications	16
Safety systems for combustion engines	17
NORINET - vessel performance management	18
NORIFID - our solution for the wireless transmission of measured values	19
Sensors and signal processing for your automation	20
Analogue indicators for your application	21
References for your automation	22

Integrated ship solutions – everything from a single source

Customised automation solutions

Backed by over 95 years of experience, NORIS offers customised ship automation solutions. As one of the few providers on the market to do so, we not only support you from the design, planning, implementation and commissioning stages through to servicing your system but we also develop, produce and market all the necessary products and components: from sensor systems through signal processing and visualisation to components and systems for complex control systems - where everything simply fits.

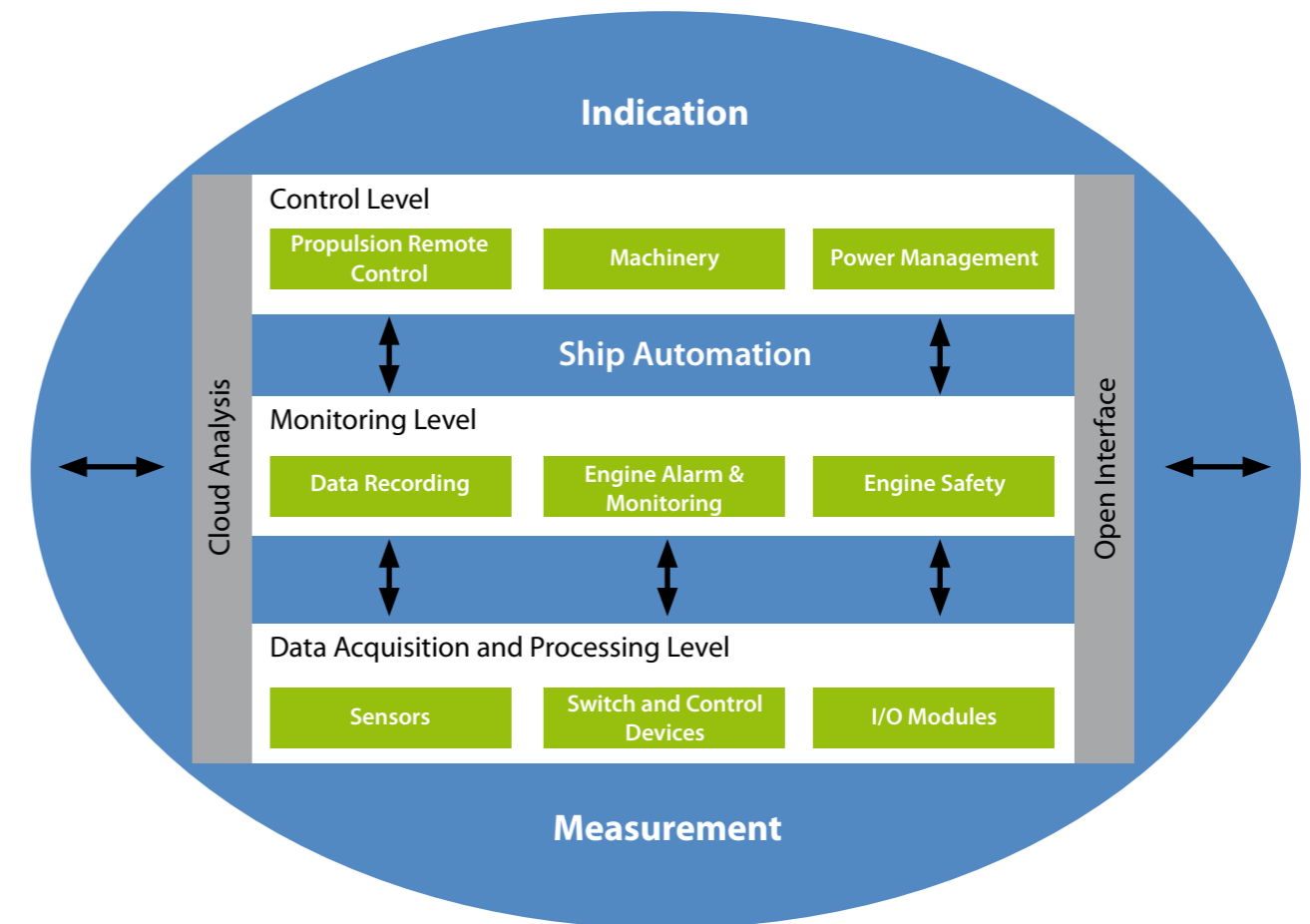

Our solutions - an overview

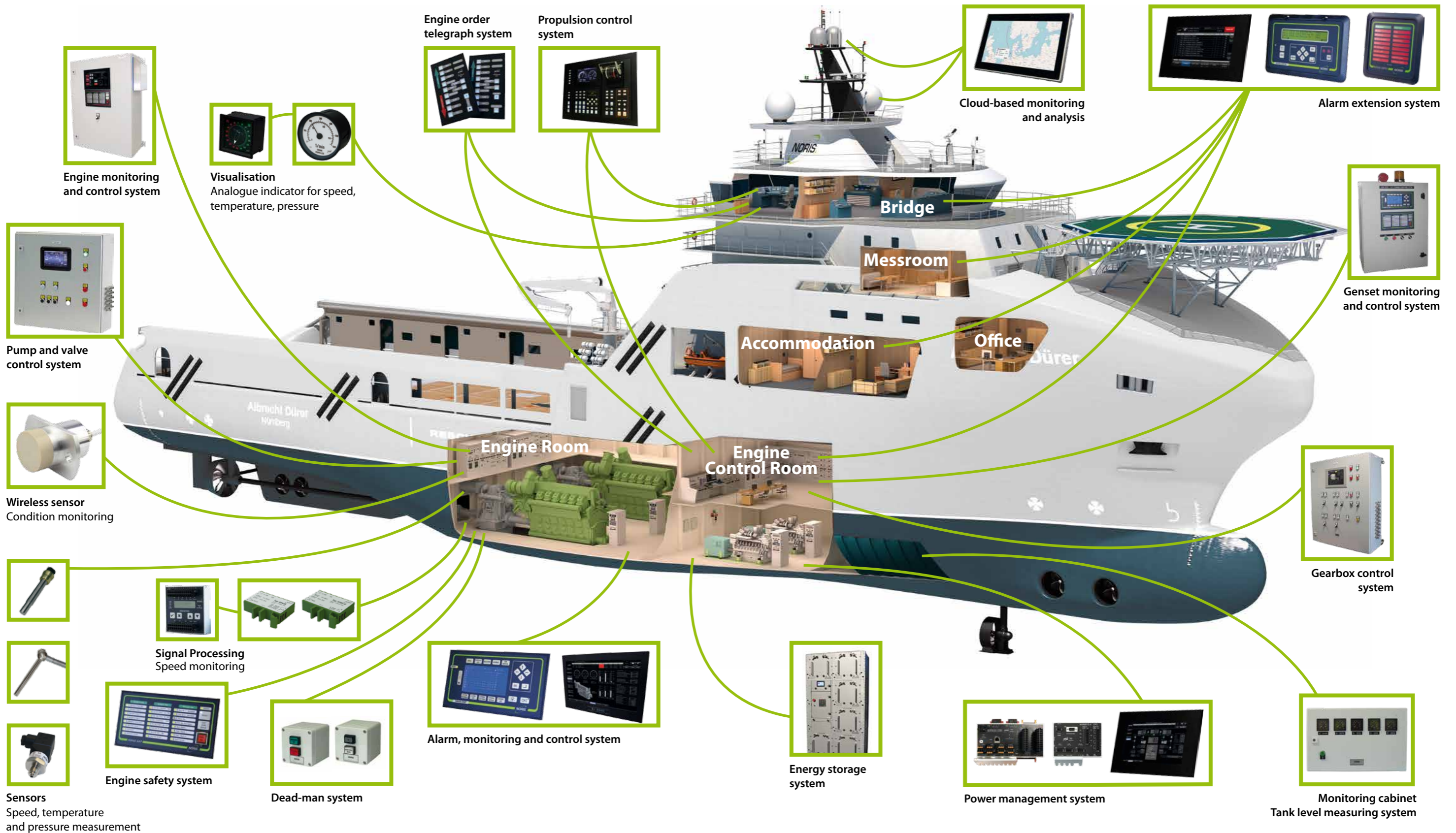

AUTOMATION SYSTEMS | Data acquisition systems | Alarm-, monitoring and control systems (AMCS) | Alarm extension systems | Safety systems for combustion engines | Power management systems | Propulsion control systems for ships | Engine order telegraphs | Tank level gauging | Dead-man systems | SENSORS | Speed sensors | Temperature sensors | Multi sensors | Wireless sensors | Speed encoders | Pressure transducers | Rotary position sensors | Tachogenerators | Sensor combinations | SIGNAL PROCESSING | Measuring transducers | Limit value switches | Multifunctional devices | VISUALISATION | Analogue indicators

NORISYS 4 – the open automation platform

The foundation for your application

We realise all automation engineering applications with our flexible and open automation platform NORISYS 4. The system is based on recognised industrial standards with perfectly matched hardware and software components as well as consistent communication design throughout. It is suitable for both simple as well as for complex applications that require maximum operational reliability under the harshest conditions:

- Simple applications: speed measuring systems, data loggers, monitoring systems, control systems for pumps, valves, fans, etc.
- Local operating panels (LOPs): gearbox monitoring and control systems, safety systems for ship propulsion and generators, start-stop systems, etc.
- Alarm, monitoring and control systems (AMCS)
- Alarm extension system/duty alarm system
- Power management systems (PMS)
- Tank level measuring systems
- Highly complex and integrated platform management system (IPMS)
- Propulsion control systems for ship propulsion
- Engine order telegraph systems

System concept

The NORISYS 4 automation platform is a flexible master-slave system featuring a central control unit that is the heart of each and every application. Further I/O components with

functionalities that cover a wide spectrum of applications are used to meet specific application requirements. Each automation system consists of one or several independent subsystems that are linked by a redundant bus. This configuration ensures maximum operational reliability. Thanks to the compact and robust design of the modules, the system is particularly suitable for use in the harshest of environments, e.g. directly next to engines and machinery.

The central control unit processes the data from the connected sensors, actuators or other systems. Equipped with a powerful 32-bit processor the system is controlled with CODESYS by a freely programmable logic controller (PLC) conforming to IEC 61131.

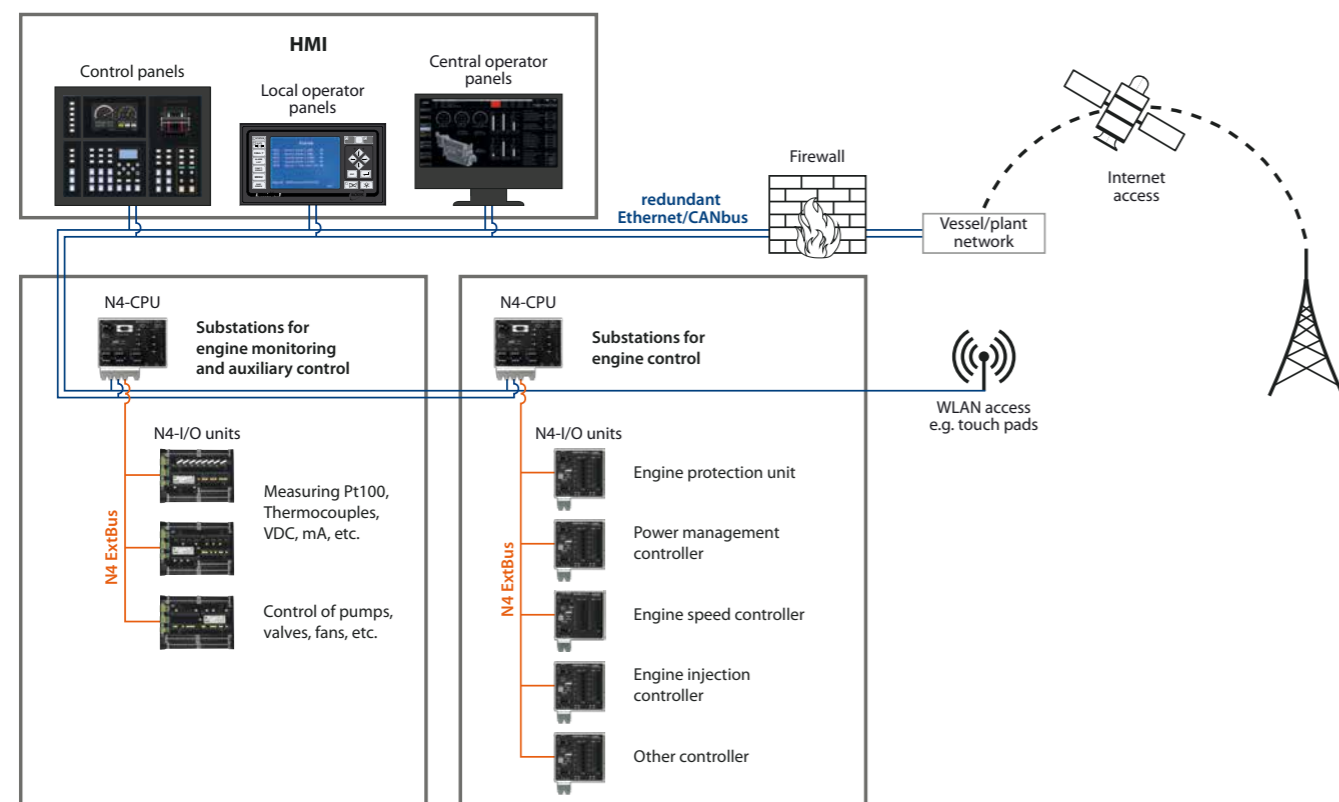

Your benefits at a glance

- Fast, multitasking 32-bit processor for processing highly complex controls
- Open communication and programming standards (PLC conforming to IEC 61131 with CODESYS) ensure a high degree of flexibility and compatibility
- Integrated web server with CODESYS Web Visualisation for fast and easy configuration
- Redundant bus systems (CANbus, Ethernet) ensure complete operational reliability
- Many application-specific modular expansions for exceptional flexibility
- Conforms to global shipbuilding standards

Integrated web server for straightforward and convenient configuration

The configuration of the NORISYS 4 automation platform is based on the powerful CODESYS software suite which was specifically developed for complex applications in industrial automation engineering and provides the user with integrated solutions ranging from engineering through visualisation to safety control and field bus technology. Straightforward configuration and parametrisation via a standard Internet browser (e.g. Internet Explorer).

The system components

Central control unit

Master module with high performance 32-bit processor, 4 digital inputs, 4 relay outputs, redundant Ethernet/CANbus interface, data logger via SD (HC) card and integrated web interface.

I/O module for 24 digital channels

I/O module for processing up to 24 digital channels, software-configurable as input or output.

Universal I/O module

for up to 8 analogue channels

I/O module configurable with up to 2 signal boards:

- AI board: 4 configurable analogue inputs, 1 digital input, 1 relay output
- AO board: 4 configurable analogue outputs, 1 digital input, 1 relay output
- Pt100 board: up to 8 Pt100 channels



NORISYS 4-CPU



NORISYS 4-24 DIO



NORISYS 4-UNIO

Product	Reference information
NORISYS 4	FL-NORISYS 4 FL-NORISYS 4-PMC DB-NORISYS 4-CPU

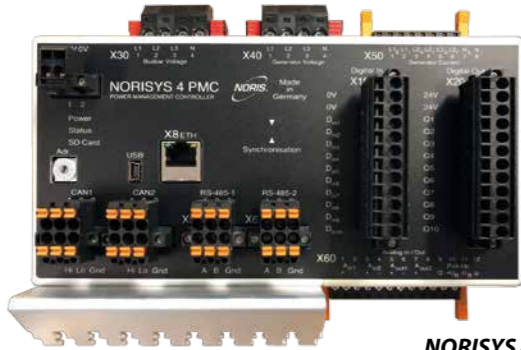

NORISYS 4-PMC

Power Management Controller

The Power Management Controller can be used as an expansion unit of the NORISYS components or as an autarkic system. In its basic version the PMC is used to connect and disconnect generators to and from the power supply system and is also suitable for use in stand-by power supply facilities. An automatic start and synchronisation function is additionally implemented to accelerate the generator set to nominal speed as well as to synchronise and close the power circuit breaker.

I/O module for 16 universal analogue inputs

I/O module for processing up to 16 universal analogue inputs in 2 or 3-wire configuration



NORISYS 4-16AI

I/O module for 16 digital inputs, 2 relay outputs, 4 analogue inputs, 4 analogue outputs

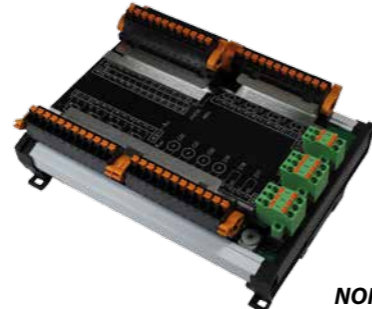

NORISYS 4-16DI-4AI-4AO

I/O module for 32 digital inputs

I/O module for up to 32 digital inputs with integrated open-circuit monitoring in 2-wire configuration or in part 3-wire configuration (of which up to 8 inputs with frequency measurement/counter function)



NORISYS 4-32DI

I/O module for 16 digital inputs and 8 relay outputs

I/O module with 16 digital inputs in 2 or, in part 3-wire configuration (of which 4 inputs with frequency measurement function), 8 relay outputs as changeover contacts, high-current, replaceable.



NORISYS 4-16DI-8R

Central operator control module

Operator control module (HMI) with redundant interface with central control units (see page 7), equipped with 12 software-configurable buttons, 4 analogue outputs, 4 digital inputs, 4 relay outputs, 2 dimmer channels



NORISYS 4-MP-12L12B

Expansion module for operator control

This operator control module (HMI) can be connected as an expansion to the central control unit (see page 7) or to the central operator control module and is available in several different versions.



NORISYS 4-SP-6L6B

NORIMOS 4 - high performance, PLC-based alarm, monitoring and control system

System concept NORIMOS 4

The N4 is our alarm, monitoring and control system (AMCS) for highest demands in operating comfort, usability, flexibility and system availability. It is used to monitor and control ship technology, such as engines, generators, pumps, valves, ventilators or other auxiliary systems. The N4 is a PLC-based AMCS with decentrally placed subsystems. Each subsystem is operating independently with a high performance I/O CPU master and its slave units and is connected to the other subsystems. The system can be easily adapted to customer requirements. With features like data logging, trend monitoring, alarm and event history and user right management, the system is ideally suitable for simple as well as sophisticated applications. Furthermore, the system can be easily extended with remote access for automatic and secure data transfer and storage to onshore data services for analysing purposes. The optional alarm extension indicates the system status at any place on board the ship. Therefore, different display versions for accommodation and bridge are available.

Your benefits at a glance

- Decentral and modular PLC-based system for maximum flexibility and failsafe operation
- Robust, reliable and approved components
- Easily expandable for your application
- Easy-to-customise thanks to modular design
- Customer-specific mimics
- Integrated web server for remote access and secure data transfer
- Powerful alarm extension system
- Worldwide service
- Class approvals: ABS, BV, DNV-GL, LR (in preparation)

Visualisation for maximum flexibility

The NORIVIS 4 visualisation software makes system information available on the screen in an application-oriented and comfortable way on data viewing stations (PCs), on displays in the engine control room, office, on the bridge or any other location on the vessel.

Product	Reference information
Alarm, monitoring and control system NORIMOS 4	FL-N4

Decentral PLC-based AMCS

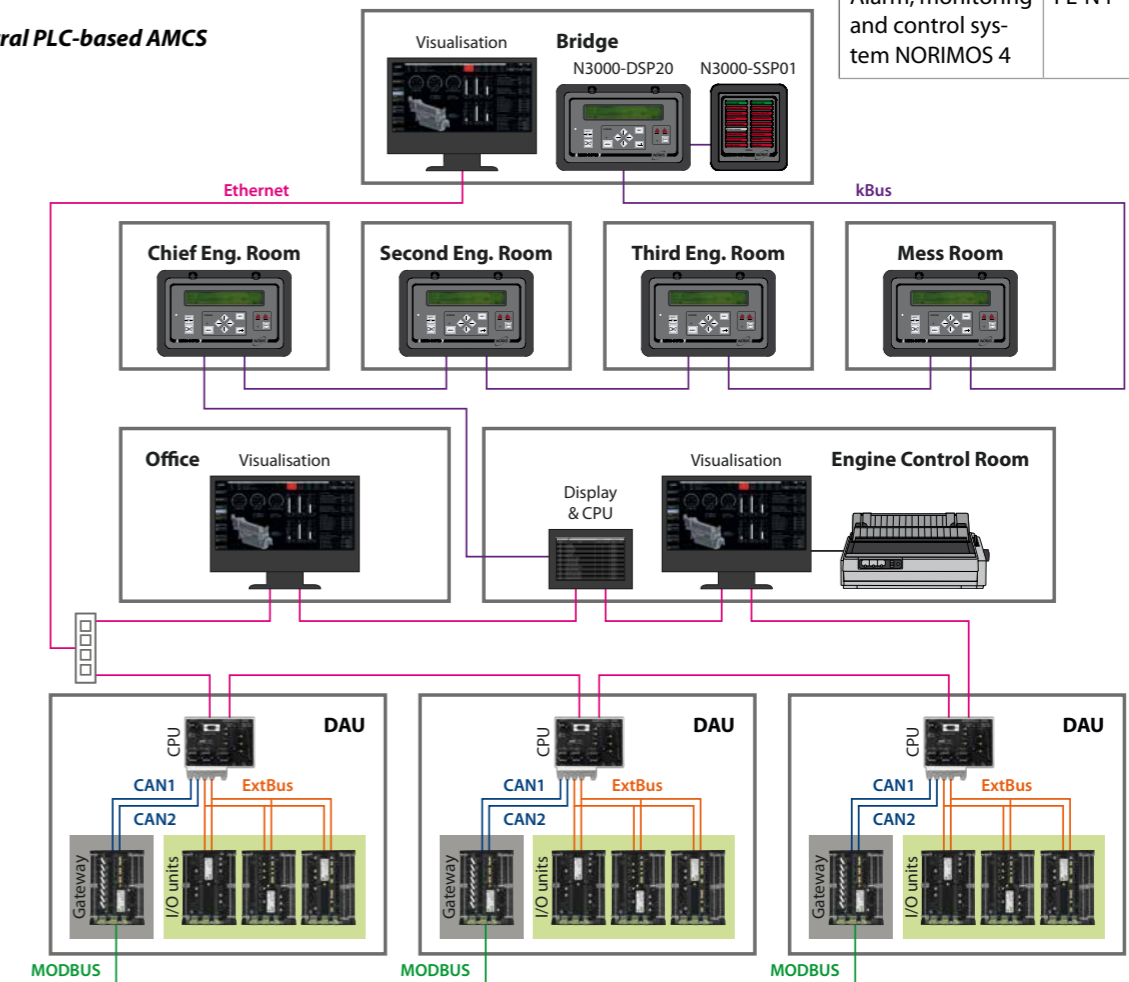

NORIMOS 3500 – cost-effective, computer-based alarm, monitoring and control system

System concept NORIMOS 3500

The N3500 is our solution for a cost-effective alarm, monitoring and control system of the well-known NORIMOS family. It is used to monitor and control ship technology, such as engines, generators, pumps, valves, ventilators or other auxiliary system. The N3500 as a centralised system is based on two central PC master stations that are acquiring and monitoring the measurement data from the connected I/O modules. It can be easily extended to customer requirements. With up to 9,000 I/Os and features like trend tables and automatic and daily storage of the alarm history on hard disk, the system leaves sufficient space for different applications and thus, it is ideally suitable for both small data acquisition systems and complex alarm, monitoring and control systems. The optional alarm extension indicates the system status at any place on board the ship. Therefore, different display versions for accommodation and bridge are available.

Secure redundant system communication

The redundant communication via CANbus and Ethernet ensures maximum system availability. All system components are designed redundantly and even in case of failure of single components, the system can still be operated.

Your benefits at a glance

- Central and modular system, easily expandable for your application
- Cost-effective due to components with standardised functionality
- Redundant system communication
- Made for reliable operation under extreme conditions
- Powerful alarm extension system: High-resolution displays for demanding graphical indication for bridge and accommodation
- Customisable mimics
- Worldwide service
- Class approval: BV, ABS, DNV-GL, CCS (others on request)

Product	Reference information
Alarm, monitoring and control system NORIMOS 3500	FL-N3500

Central computer-based AMCS

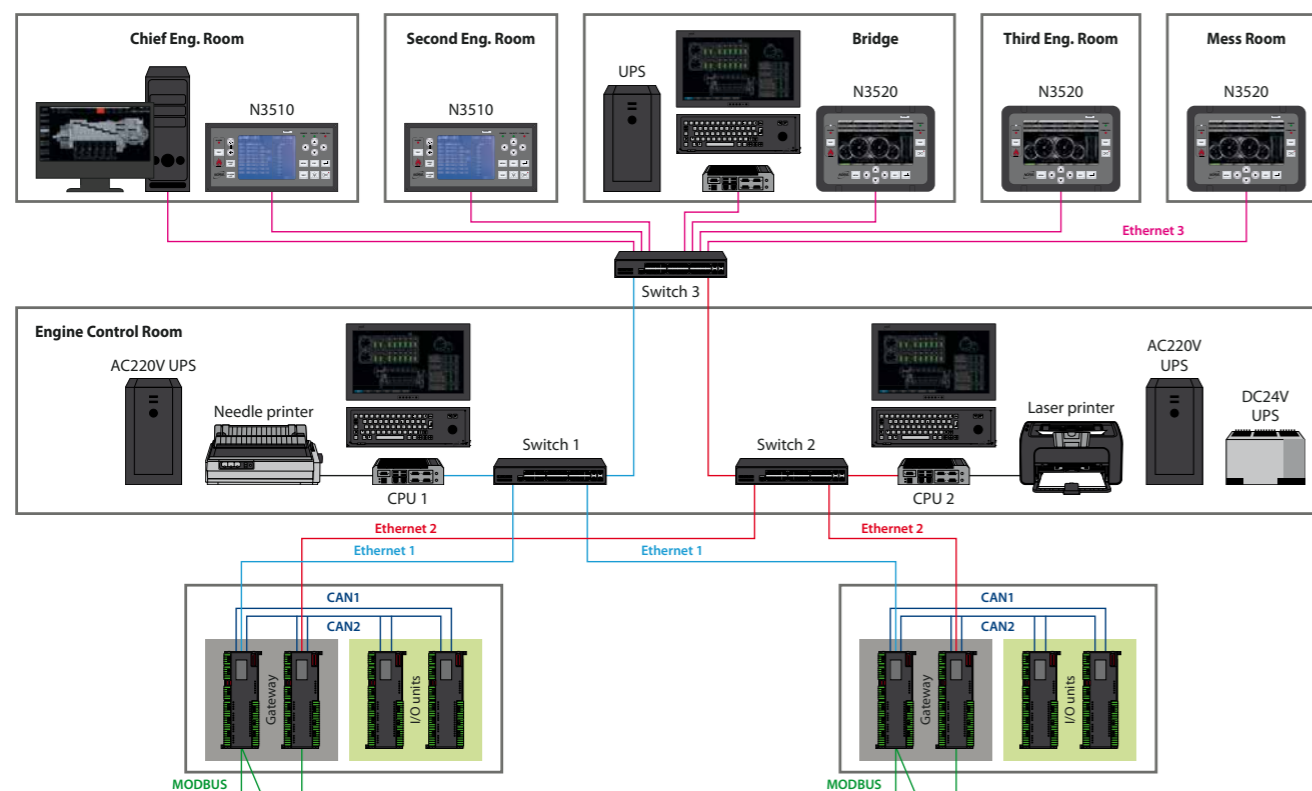

NORISTAR 4 – the propulsion control system for your ship

System concept NORISTAR 4

NORISTAR 4 is a modular and flexible propulsion control system and our solution for fixed propeller, variable-pitch propeller, Azipod and diesel-electric propulsion systems and various belt drive systems. The system is based on the central control unit and I/O components of the NORISYS 4 automation platform (see page 7). Several versions of the control desk are available for remote propulsion control on the bridge, aft bridge and wing control stands. Each control desk can be expanded with various operator control panels and can be easily adapted to any customer-specific application or requirement. All system components are interconnected by state-of-the-art field bus technology. The redundant bus concept of the control desk ensures maximum operational reliability.

Interfaces with external systems

The propulsion control system can be connected via a bus link to the Integrated Bridge System (IBS). An interface with the Voyage Data Recorder (VDR) is also integrated in the system.

Commissioning and service

Straightforward system configuration takes place on a touch screen display with a menu-supported user interface with the central control unit. The intuitive and standardised operating procedures allow customers to perform the commissioning procedure for the propulsion control system themselves.

Your benefits at a glance

- For CPP, FPP, POD and all types of thruster systems
- Can be adapted to any propulsion application
- Integrated protection to prevent engine overloading
- Defined control programs for various operating modes
- Integrated NFU control
- Interfaces with external systems (e.g. VDR, IBS, etc.)
- Integrated touch panel display for user-friendly configuration and monitoring
- Easy installation
- Commissioning by customer possible
- Maximum availability backed by worldwide service
- Optionally available with additional functions: Load distribution, electronic synchronisation, start-stop logic, connection to dynamic positioning and joystick systems, etc.



NORISTAR 4

Product	Reference information
Propulsion control NORISTAR 4	FL-NORISTAR4
Control lever system LA4	DB-NLA4
Control lever system LS4	DB-NLS4
Control lever system LT4	DB-NLT4

Propulsion control system concept

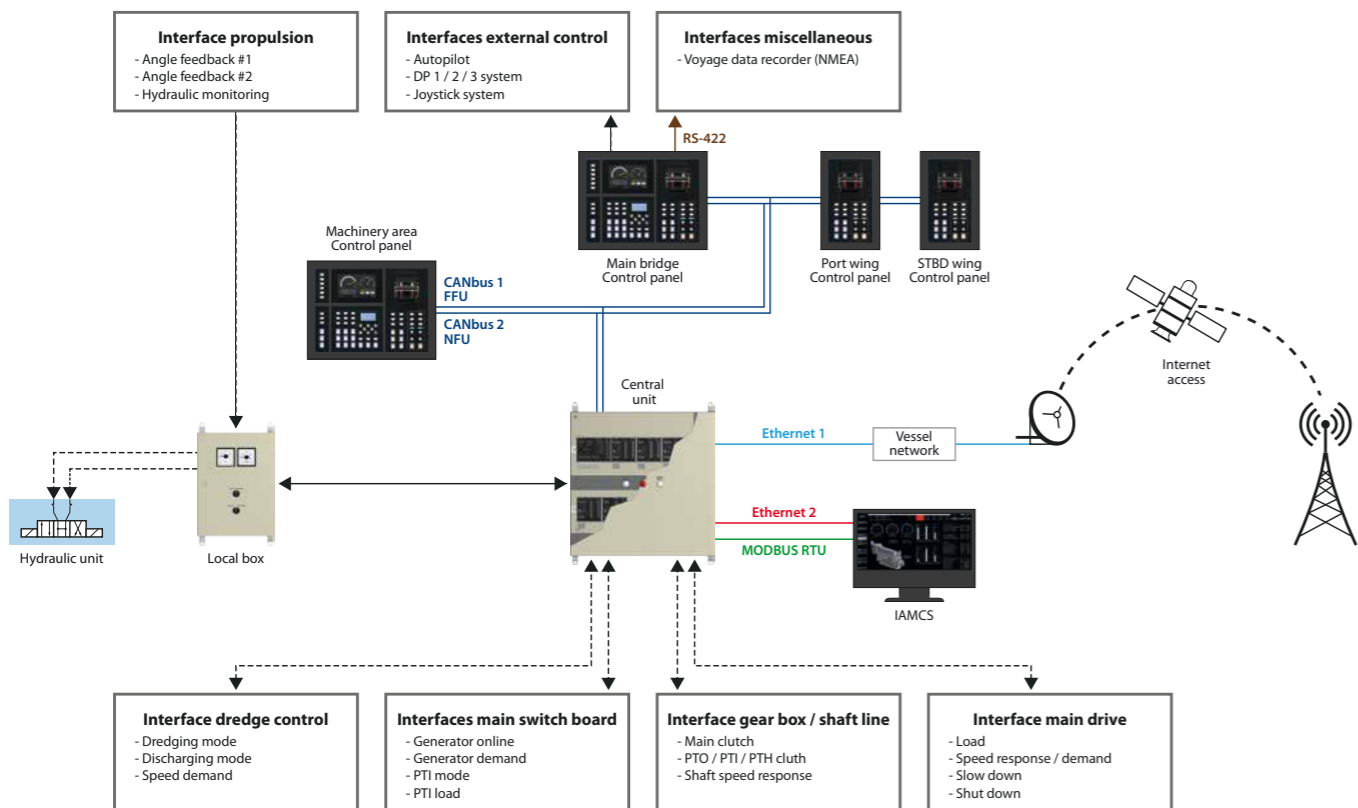

Control lever systems for ship propulsion

System concept NORISYS control lever system

The NORISYS 4 control lever system was developed for shipboard propulsion systems and is our solution for propulsion control applications. It is the ideal addition to the propulsion control system. The control lever is available as a single or double control lever with a simple design (with potentiometric or analogue standard signal outputs) or as a fully electronic version with integrated data interface and can be configured customer-specific for any application.

Communication with other automation systems

The fully electronic version of the control lever can be connected to any automation system via a redundant CANbus or via the integrated RS-485 interface with MODBUS-RTU or the ExtBus protocol of our NORISYS 4 automation platform.

Your benefits at a glance

- Available as a single or double control lever
- Version also available for azimuthing and transverse thrusters
- Different scales available for each control lever
- Position indicator for each control lever
- Optionally with electrical shaft function and force feedback for each lever
- Configurable for different applications
- Factory preconfigured for easy installation and commissioning by customer
- Suitable for indoor and outdoor applications
- Interfaces: 2x CANbus or 1x CANbus + 1x RS232/485

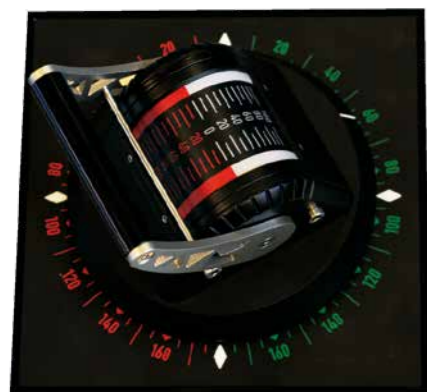

NORISYS 4 LA4



NORISYS 4 LS4



NORISYS 4 LT4

NORISTAR-EOT - engine order telegraph system

System concept

The NORISTAR-EOT is an emergency communication system used to transfer vital commands between the wheelhouse and engine room fast and reliably. Up to 12 engine order telegraphs can be integrated in a master-slave system. Different versions are available for the bridge (ahead/astern) and engine room or engine control room.

Each engine order telegraph is equipped with 11 order buttons. When an order button is pressed on a master unit on the bridge, the order is signalled visually by the corresponding button flashing and acoustically by an integrated buzzer on the slave devices in the machine room or machine control room. The order must then be confirmed by pressing the flashing order button on the slave unit.

Your benefits at a glance

- Robust devices for use in harsh environments
- Different versions for different applications
- Up to 12 engine order telegraphs in one system
- Visual and audible alarm triggering
- Operating status indicator on each unit
- Dimmable lighting for bridge units
- 6 floating relay outputs per unit, e.g. for Wrong Way Alarm or for connecting external buzzers
- Connection to the Voyage Data Recorder (VDR)

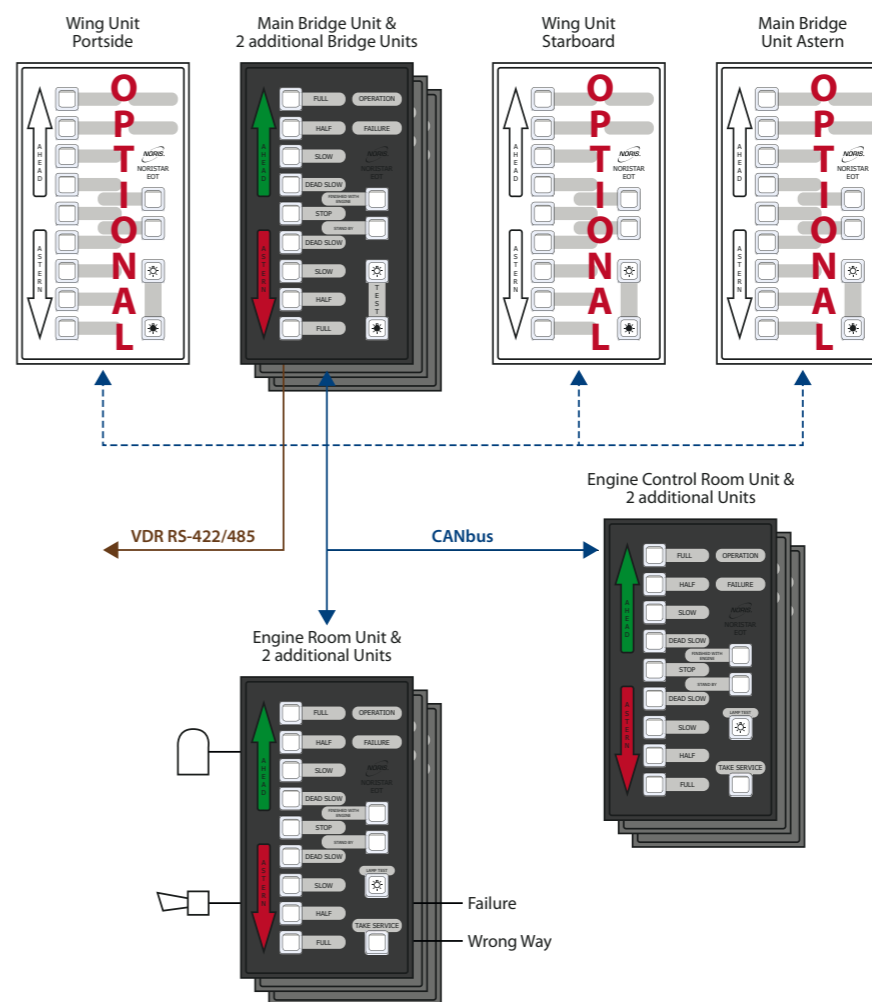

NORISTAR-EOT

Product	Reference information
NORISTAR-EOT	DB-EOT

NORISYNC 4 – power management solutions

The NORISYNC 4 power management system (PMS) optimises the generation and use of electricity. It is a customised solution, made to efficiently manage the power generation including an optional energy storage system (ESS) and the power distribution from manual to fully automated and to provide a comfortable system status overview at any time to the crew.

The system concept

NORISYNC 4 is based on our open automation platform NORISYS 4, that was especially developed to automate marine applications. Core of the system is the power management controller NORISYS 4 PMC with an ARM 32-bit Cortex™ processor. In its basic version, the PMC is used to switch generators on the power grid and is also suitable for use in stand-by power supply facilities. It is designed to be used for isolated and parallel operation. An automatic start and synchronisation function is additionally implemented to accelerate the generator, set to nominal speed as well as to synchronise and close the power circuit breaker. The system can be easily extended and customised via our NORISYS 4 components, including a PC station and remote panels as HMI that visualises the system's status and the power distribution and further customised information. The standardised interfaces easily enable the connection to propulsion control or other higher level systems.

Your benefits at a glance

- CPU based multi-master system
- Safety through redundant communication
- Remote access for maintenance and service
- Different operation modes
- Automatic shore connection
- Intelligent ESS control
- Interfaces to higher level systems
- Usable in DC-power-bus applications
- Class approvals: BV, DNV-GL, LR (in preparation)

Product	Reference information
Power management solutions	FL-PMS

NORISYNC 4 system overview

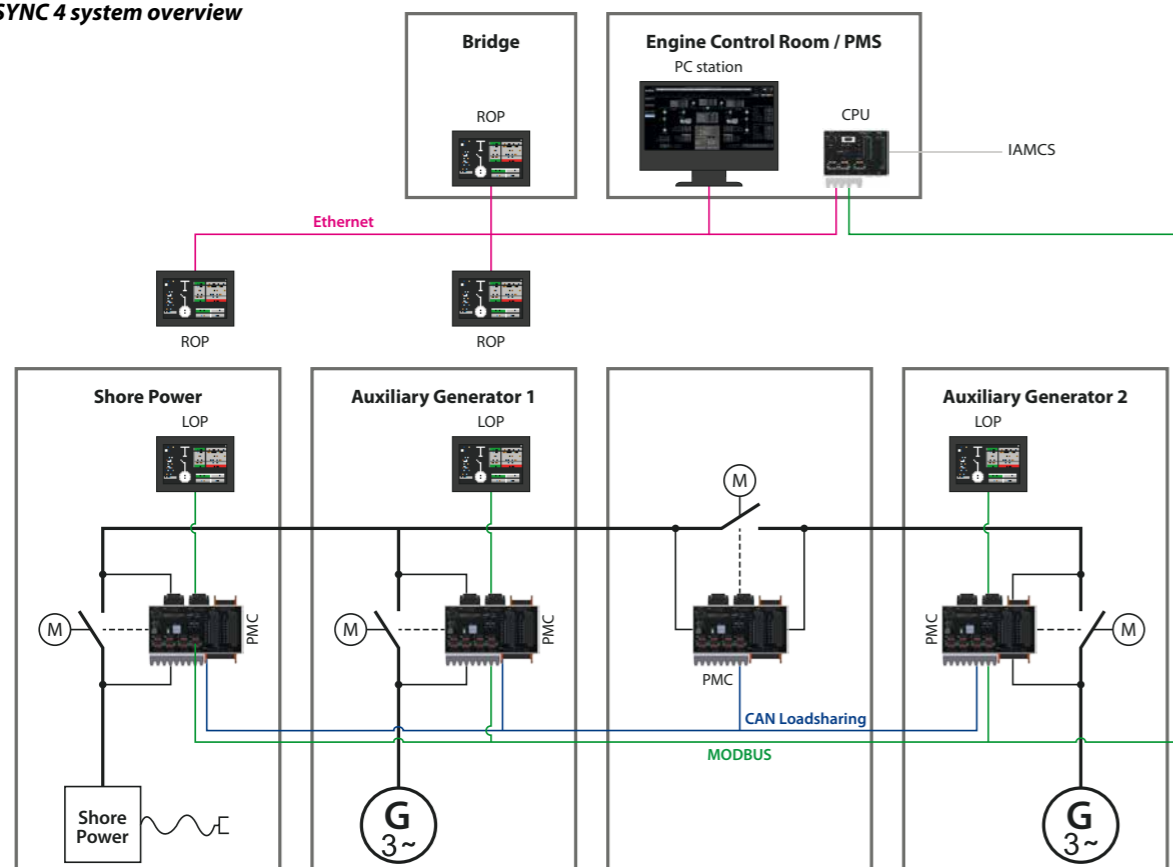

Energy storage solutions – for the most efficient use of energy

For hybrid and fully electric systems on ships, the energy storage is an essential part and has to be designed in regard to the respective challenging application performance. Thus, we offer you customised solutions with a well-established and safe energy storage system (ESS) that is already in use in numerous projects – from fish farming vessels and ferries to offshore supply vessels and also on mega yachts, not to mention the numerous onshore industrial applications. Our ESS solution is based on liquid cooled, encapsulated high power battery modules and is currently one of the safest in the world. The modular system concept makes it easy to customise your energy storage solution exactly to your application. The batteries come as „plug & play“ modules and are installed in modular racks. This ensures an easy installation and replacement and reduces purchase and maintenance costs. And even when the system is outdated, it is not necessary to acquire a new system, because it can be easily renewed by replacing the components – a cost-effective and sustainable solution.

Application and Features

- Power Mode: Providing high energy in short time
- Energy Mode: Providing constant energy level over long time
- Peak Shaving Mode: Providing punctually energy to avoid load peaks
- Harbour Mode: Generate power without running your Diesel generators or without shore connection – clean and silent!
- “Bring me to harbour” Mode: Your redundant system for propulsion – no noise, no pollution.

CellSwap™ Advantages

Traditional battery systems require the entire system to be replaced at end of life – but not with CellSwap™: The process is simple and safe. The cell stack easily separates from the electrical controls. The new cell stack is pre-assembled in the SPBES factory in Norway and shipped to the vessel for installation. Old cell stacks are refurbished in the factory and reused and thus, CellSwap™ helps to protect the environment.

PBES CellCool™ Liquid Cooling

Traditional ESS are based on air cooled batteries. Disadvantages of these batteries are increased aging and thus, a reduced life cycle and also the problem of overheating and inflammation in case of peak loads. The PBES CellCool™ Liquid Cooling ensures a uniform temperature across the battery cells and thus, a uniform battery aging. Furthermore a temperature sensor on each cell is used for overheating monitoring and allows to observe bad cell behaviour developing over time. An external air conditioning system, as it is used for air cooled solutions, is also not necessary. This is the safest way for your application.

Product	Reference information
Energy storage solutions	FL-ESS

NORIS Automation GmbH is a registered solution partner of SPBES <http://www.pbes.com/>



Your benefits at a glance

- Individual consulting for your application from experts
- Safe and reliable energy storage due to PBES CellCool™ Liquid Cooling
- High performance XALT Lithium-ion cells (3C rating) for maximum power and performance
- Simple integration into both new buildings and retrofits
- Modular concept (CellSwap™) ensures customisable power and easy maintenance
- Simple installation in various configurations due to modular racks
- Reduced blackout risk through operating ESS
- Optimised fuel consumption and lower engine maintenance costs through efficient energy usage
- Reduced number of generator start/stops or even saves space due to the fact that less generators are necessary
- Project-specific class approval for any of the major classes (ABS, BV, DNV-GL, LR)



myNORIS – smart automation solutions for propulsion, gearboxes and engines

Expandable system concept

We develop smart solutions for machinery automation in one-off or series production. They can be used to monitor and control engines, gearboxes, drive systems and auxiliary systems. Each solution is engineered to customer-specific requirements and can be easily extended with additional displays for decentral visualisation or additional operating panels to provide local operation. Standard interfaces, such as MODBUS, J1939, CANopen, Profibus or NMEA enable a simple integration into third-party systems. The intuitive visualisation is based on the powerful CODESYS (IEC 61131) software suite and can be easily adapted to customer's corporate design. All components are especially suitable for the use in harsh environments and ensure maximum operational reliability.

Construction and customised mechanical design

The mechanical design of our LOPs is manufactured to your requirements for vibration and shock resistance. To ensure the recognition of system changes and to enable the planning of your maintenance cycles (predictive maintenance), detailed system response calculations can be integrated on request. In addition, a 3D modelling of the LOP simplifies the involvement during your planning phase.



Indicator remote panel

myNORIS gearbox control



Display remote panel

Your benefits at a glance

- Local availability of measurement data, operating states and control functions
- High-resolution, graphic depiction of operating states
- Integrated data logging
- Standardised interfaces to higher-level systems (AMCS, RCS, IPMS, etc.)
- Predictive maintenance
- Easy firmware and software update via USB
- Extensive project and installation support
- Integrated safety logic
- Remote access during servicing
- Various expansion levels

Application examples

We engineer each LOP to your specific applications:

- Propulsion engine
- Reduction gear-box
- Hybrid gear-box
- Trolling clutch
- Genset
- Others (e.g. winches, separators, purifiers, fresh and waste water treatment)

Product	Reference information
myNORIS LOPs	FL-myNORIS
myNORIS AMCS	FL-myNORIS-AMS

Safety systems for combustion engines



N3000-SAP

System concept

The N3000-SAP safety system monitors the primary operating parameters of an engine. It is the central unit for triggering an emergency shut-down of the engine to avoid damage. Thanks to its compact yet robust design, the safety system is particularly suitable for use on ships and can be installed directly on the engine. Signal processing is purely digital. Together with fast and quartz-precise speed acquisition it ensures maximum safety and system reliability. A large number of preprogrammed engine types and the straightforward class-compliant configuration enable fast adaptation to existing applications.

System availability

In addition to a redundant operating voltage, the system availability is guaranteed by several internal monitoring functions:

- Operating voltage monitoring
- Input earth fault monitoring
- Input open-circuit monitoring
- Pick-up signal discrepancy monitoring

Product	Reference information
Engine safety system N3000-SAP	FL-N3000-SAP

Clear visualisation of channel status

Relating to the measuring point, the channel statuses are indicated by three-colour status LEDs. Each LED is arranged on the front next to a labelled text field highlighted in colour.

System flexibility and scalability

The safety system can be expanded with our automation components to integrate a data logger or a start-stop system for example. As a further advantage, the interfaces of our components with other systems are then available (via MODBUS protocol or Ethernet).

Your benefits at a glance

- Suitable for almost all types of combustion engines
- Fast and quartz-precision speed acquisition
- Fast and reliable engine shut-down by open circuit monitored shut-down outputs
- Large number of preprogrammed engine types set via coding switches for easy configuration
- User-friendly installation in the control cabinet door
- Plug-in connections for easy servicing (screw or spring-type terminals)

NORINET – vessel performance management

System concept

NORINET is based on the latest maritime 4.0 infrastructure. The NORINET interface unit is installed on the vessel with access to the internet and connected to the vessel's LAN network. It works as data collector, processor and gateway. The secure data transfer from the interface unit to the cloud is done via MQTT messaging protocol and ensures minimum network traffic and maximum scalability. Data from the alarm, monitoring and control system (AMCS) and navigation data is transferred via GPRS to an onshore server into the NORINET cloud. These data can be accessed via internet with multiple clients (PC, tablet or smart phone with a standard web browser).

Application-based cloud service

NORINET cloud service is based on Applications (Apps). This allows the user to select and use specific features and functions. The NORINET applications can be customised, if necessary, to meet your requirements.

Vessel reports and predictive maintenance

Apart from the live view the NORINET cloud data can be used to generate customer-specific reports (e. g. Efficiency report, SFOC/FOC, power report, hull cleaning, engine condition, etc.). Thus, it is possible to observe your vessel's performance and to schedule service and maintenance.

NORINET system structure

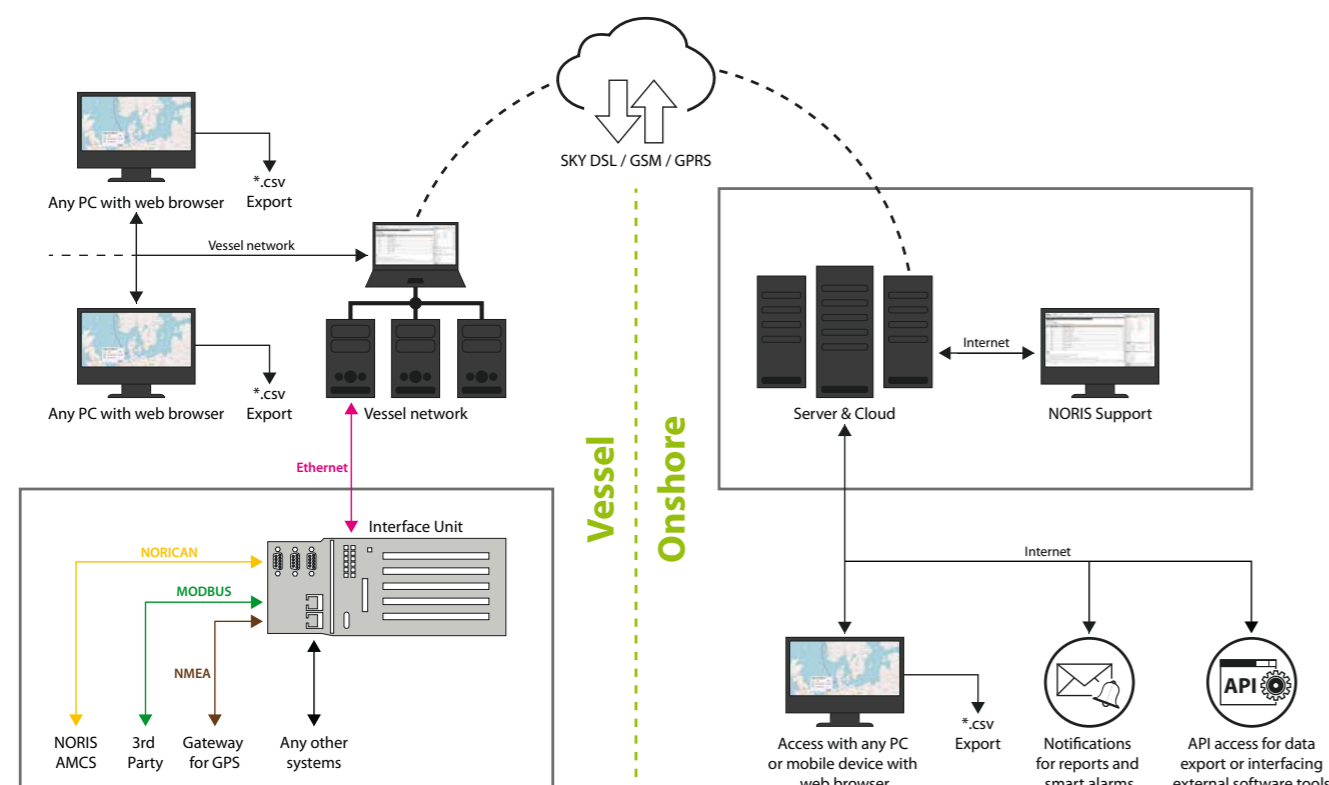

Your benefits at a glance

- Fast, reliable and secure data transfer via MQTT protocol
- Data caching when internet connection is interrupted
- Optimisation of vessel and fleet performance as well as maintenance processes
- App-based functionality to ease customisation and to reduce costs
- Secure real-time remote monitoring
- Performance reports and analysis based on historical data
- Easy system updates
- User management and multiple user access

Product	Reference information
NORINET	FL-NORINET

NORIFID – our solution for the wireless transmission of measured values

Predictive maintenance needs measured data to the greatest possible precision. On components with moving or rotating parts, the relevant variables (e. g. temperature of an electric motor's rotor or planetary gearbox bearing) sometimes cannot be accessed with wired sensors. Accordingly, the data needed for condition monitoring can be obtained only with complex calculations and estimates. However, precise and reliable measured data are obtained only when a sensor is placed directly on the moving part. For requirements of this kind we have developed **NORIFID**, a simple, cost effective measuring system that is based on established technologies, supplies wirelessly power by induction to a sensor on a moving part, and transmits the measured data via **RFID** to a fixed receiver.

System setup

NORIFID consists of a reader that is fitted on the fixed component and a transponder with measuring element attached to the moving component. This measuring element can be a fixed integral part of the transponder or, if necessary, placed outside of the measuring site and wired to the transponder.

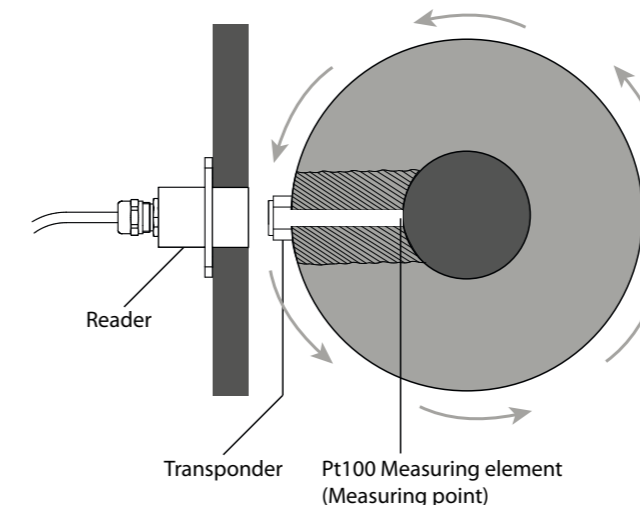

Functional principle

Power and data are transmitted wirelessly by induction, via an RF magnetic field (13.56 MHz **RFID**). The reader consists basically of a transformer, analysing electronics, and a signal converter and is supplied with voltage from an external source. The transponder likewise is fitted with a transformer, an integrated circuit, and a Pt100 measuring element and is installed on the moving object. It operates passively and therefore does not require its own power supply. The transponder positioned on the rotating object moves cyclically past the reader. When the transponder enters the reader's range, the reader's alternating magnetic field induces a voltage in the transponder coil, supplying it with the necessary power. Once the transponder is in the reader's active zone, its connected Pt100 measuring element detects the temperature and transmits the measurement value immediately and wirelessly to the reader. Depending on the requirements, the reader then converts and outputs the measurement signals as a voltage or current value.

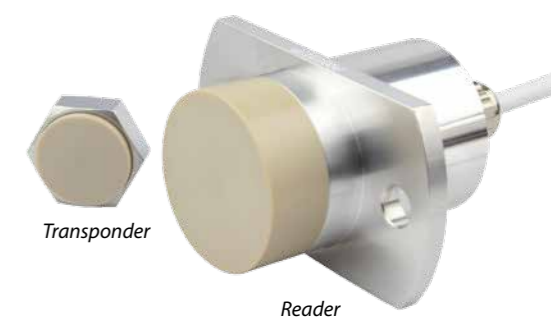

Your benefits at a glance

- **NORIFID** measures values on moving parts
- Reliable, robust **RFID** data transmission (13.56 MHz)
- Maintenance-free system (transponder without battery)
- Compact system with small installed height
- No large analysis unit necessary
- Low cost and reliable thanks to established technologies
- Various output signals

Application examples

- Winding temperature measurements on an electric motor's rotor
- Bearing temperature measurements in planetary gearing
- Temperature measurements on torsional vibration dampers
- Temperature measurements on connecting rod bearings

Product	Reference information
NORIFID	FL-WLS

Sensors and signal processing for your automation

We have been there from the very beginning. As one of the few manufacturers of automation components, we have gained more than 95 years of experience in the sensor, signal processing and visualisation sectors. Whether speed measurement for your ship propulsion, measurement of exhaust gas, oil, coolant and bearing temperatures, recording pressures in hydraulic systems or registering angle positions on mounted shafts: we have available the right sensors and signal processing devices for your system. Our products are designed to reliably operate for years under the most extreme environmental conditions in safety applications.

Speed sensors

Our speed sensors are used in speed measuring systems for engines, gearboxes, generators as well as in other machinery.

- Non-contact or mechanically driven sensors (pick-ups, tachogenerators)
- Various designs and different connections
- A range of measuring principles: Difference-hall, inductive-magnetic or eddy current for scanning ferromagnetic or aluminium gearwheels
- Different enclosure materials (e.g. stainless steel, aluminium)



Pressure transducers

You will find our pressure transducers on engines and gearboxes for measuring the lubricating oil pressure, on hydraulic and pneumatic pumps, on filters, compressors and pressure tanks as well as on tank installations for measuring fluid levels.

- Registering pressure of liquid and gaseous media
- Absolute and relative pressure measurement
- Standard signals 4...20 mA, 0...10 V
- With different connections



Temperature sensors

Our temperature sensors are used to measure exhaust gas, oil, coolant and bearing temperatures.

- Different designs, different immersion depths, different measuring elements: Pt100/Pt1000, NTC thermistors, thermocouples
- Different enclosure materials: brass, stainless steel, CuNiFer
- Enclosure protection class up to IP68



Multi sensors

- Up to three sensors in one enclosure for combined measurement of speed, temperature and acceleration (vibration)



Rotary position sensors

- For precisely registering angular positions
- Mounted directly on the drive shaft
- Maintenance-free



Signal processing devices

Our signal processing devices are used for monitoring limits and converting measured values in speed measurement systems or to make available additional output signals for further control systems.

- Measuring transducers for frequency and temperature
- Limit value switches for frequency, temperature, DC and AC voltages
- Multifunctional devices for measuring up to two speed signals with slip and offset measurement, 2 galvanically isolated signal outputs and 6 relay outputs



Analogue indicators for your application

Our indicator instruments feature stepper motor technology or are equipped with a moving-coil element. They are primarily used wherever great demands are placed on durability and reliability. The high electromagnetic compatibility as well as the immunity to shock and vibration as stipulated by the ship classification bodies enable continuous use under increased mechanical stress conditions.

We make instrumentation to your specification

Whether to indicate speed, temperature, pressure, propeller pitch or rudder position. We make instrumentation to your specifications. In addition to different designs (round or square) and sizes, you can define the scale, scale colour, limit range, pointer lighting and much more. Additional functions are available on request, e.g. integrated direction of rotation detection for measuring the speed of reversing propulsion systems, a status LED for showing when limits are exceeded as well as additional signal or relay outputs for signal processing.



Product	Reference information
Sensors, signal processing devices, indicators	BR-NAN-Overview
Speed sensors	FL-FAHU52, FL-FAW, DB-FA5, DB-FA13, DB-FA52, DB-FA54, DB-FAH12, DB-FAH52, DB-FAHU52, DB-FAHZ53, DB-FAJ12, DB-FAW52
Temperature sensors	BR-NAN-TempSens, DB-T.3., DB-TA, DB-TAV, DB-TH., DB-TP
Multi sensors	FL-KA
Speed encoders	DB-NAD
Pressure transducers	DB-PAX9, DB-VD61
Rotary position sensors	DB-DWA
Tachogenerators	DB-GE, DB-GZ
Multifunctional devices	DB-FMN6
Limit value switches	DB-R...
Measuring transducers	DB-V...
Analogue indicators	FL-NIR-NIQ, FL-NIQ31, FL-SIR-SIQ, DB-NIR3/NIQ3, DB-NIQ31, DB-SIR3/SIQ3

References for your automation

We have been there from the very beginning. As one of the few manufacturers of automation components, we have gained more than 95 years of experience in the sensor, signal processing and visualisation sectors. Whether speed measurement for your ship propulsion, measurement of exhaust gas, oil, coolant and bearing temperatures, recording pressures in hydraulic systems or registering angle positions on mounted shafts: we have available the right sensors and signal processing devices for your system. Our products are designed to reliably operate for years under the most extreme environmental conditions in safety applications.

more than 400
alarm, monitoring and
control systems

over 500 engine safety systems

more than 750 propulsion
control systems

...in the last 8 years

more than 1000
new buildings

more than
200 retrofits

...in the last 8 years

more than 500 bulk carriers
more than 400 specialised vessels
over 60 tankers

over 20 yachts

...in the last 8 years

more than 20000 sensors

more than 50000 radiosondes

from our subsidiary
GRAW Radiosondes

...are produced and
delivered every year

Besides common automation systems, we project systems for special applications:

Funnel Lowering for
Quantum Class

Measurement Systems
and Analysis of
Fuel Oil Consumption

Rack-Chock Control System
MUHIBAH

Tank Level Measuring

Jackup-rig Leg Control

Fire Fighting Control Systems

Exhaust Gas Scrubber
Control Systems

Stabilizers Control
Systems

Balast Control System

Load Synchronisation for a number of
engine equipment

Since 1925 there has
been actually only a few
vessels left where there is
not installed a product
from NORIS.

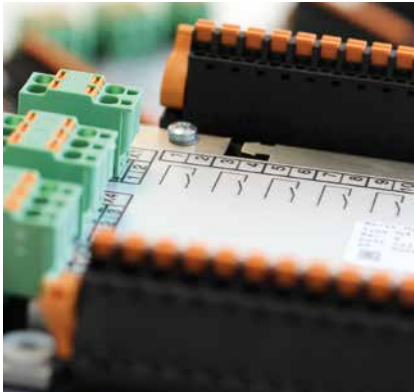

NORIS Group GmbH
 Muggenhofer Str. 95
 90429 Nuremberg
 Germany

Phone: +49 911 3201-0
 Fax: +49 911 3201-150
 info@noris-group.com
 www.noris-group.com

■ Nuremberg ■ Rostock ■ Rotterdam ■ Singapore ■ Shanghai